



Smart Architecture of Espadana
Designing, Production, Customization and Consultant Service
in Network and Fiber Optic System



Technical Specification

SAE-TGSS2733-10

10G 1270nm Tx-1330nm Rx/1330nmTx-1270nm Rx, 40km, 3.3V, LC DDM





Product Description

- Optical interface compliant to IEEE 802.3ae 10GBASE-LR
- Data rate 10Gbps
- Electrical interface compliant to SFF-8431
- Hot Pluggable
- 1270nm Tx FP transmitter, PIN photo-detector(TYPE A)
- 1330nm Tx FP transmitter, PIN photo-detector(TYPE B)
- Operating case temperature: 0 to 70 °C
- Low power consumption
- All-metal housing for superior EMI performance
- Advanced firmware allow customer system encryption
- information to be stored in transceiver
- Cost effective SFP+ solution, enables higher port
- Applicable for 40km SMF connection

Full Description

SAE-TGSS2733/3327-40 is a very reliable and high performance in order to transmit 10G network data on optical cores. The SAE-TGSS2733/3327-40 1270 nm FP 10Gigabit SFP Tx transceiver & 1330nm Rx is designed to transmit and receive optical data over single mode optical fiber for link length 40km. The SFP 40km module electrical interface is compliant to SFI electrical specifications. The transmitter input and receiver output impedance is 100 Ohms differential. Data lines are internally AC coupled. The module provides differential termination and reduce differential to common mode conversion for quality signal termination and low EMI. SFI typically operates over 200 mm of improved FR4 material or up to about 150mm of standard FR4 with one connector.

SAE-TGSS2733/3327-40 made by high quality of components were rigorous screened, have superior performance in stability, environmental adaptability. The product planned in a way of better resistance and ability to corrosion and electromagnetic interference.



Applications

- 10GBASE-LR at 10.3125Gbps

Technical specification

Product name	SAE-TGSS2733-40
---------------------	-----------------

Table 1 - Absolute Maximum Ratings

Parameter	Symbol	Min	Max	Unit
Storage Temperature	Ts	-40	+85	°C
Supply Voltage	Vcc	-0.5	+4.7	V
Case Operating Temperature	Tcase	-5	70	°C



Table 2- Optical and Electrical Characteristics

Parameter	Symbol	Min	Typical	Max	Unit	Note
Transmitter section						
Centre Wavelength	λ		1270		nm	
Out put Opt.Pwr	POUT	-6		-0.5	dBm	1
Wavelength Temperature Dependence			0.08	0.125	Nm/°C	
Spectral Width (-20dB)	σ			1	nm	
Optical Extinction Ratio	ER	3.5			dB	
Transmitter and Dispersion Penalty	TDP			3.2	dB	
Optical Rise/Fall Time	Tr/tf		0.1	0.26	ns	
RIN	RIN			-128	dB/Hz	
Output Eye Mask	Compliant with IEEE 0802.3a					
Receiver section						
Rx Sensitivity	RSENS			-15	dBm	2
Centre Wavelength	λ		1330		nm	
Input Saturation Power (Overload)	Psat	-3			dBm	
Wavelength Range	λ_C	1270		1610	nm	
LOS De -Assert	LOSD			-17		
LOS Assert	LOSA	-30			dBm	
LOS Hysteresis		0.5	1.0		dB	

Notes:

1) Class 1 Laser Safety per FDA/CDRH and IEC-825-1 regulations.

2) With worst-case extinction ratio. Measured with a PRBS 231-1 test pattern, @10.325Gb/s, BER<10⁻¹².



Notes:

- 1) Circuit ground is internally isolated from chassis ground.
- 2) TFAULT is an open collector/drain output, which should be pulled up with a 4.7k – 10k Ohms resistor on the host board if intended for use. Pull up voltage should be between 2.0V to $V_{cc} + 0.3V$. A high output indicates a transmitter fault caused by either the TX bias current or the TX output power exceeding the preset alarm thresholds. A low output indicates normal operation. In the low state, the output is pulled to $<0.8V$.
- 3) Laser output disabled on $T_{DIS} > 2.0V$ or open, enabled on $T_{DIS} < 0.8V$.
- 4) Should be pulled up with 4.7k Ω - 10k Ω host board to a voltage between 2.0V and 3.6V. MOD_ABS pulls line low to indicate module is plugged in.
- 5) Internally pulled down per SFF-8431 Rev 4.1.
- 6) LOS is open collector output. It should be pulled up with 4.7k Ω – 10k Ω on host board to a voltage between 2.0V and 3.6V. Logic 0 indicates normal operation; logic 1 indicates loss of signal.

Electrical Interface Characteristics

Parameter	Symbol	Min	Typical	Max	Unit	Note
Transmitter section						
Input differential impedance	Rin		100		Ω	1
Single ended data input swing	Vin,pp	180		700	mV	
Transmit Disable Voltage	VD	Vcc-1.3		Vcc	V	
Transmit Enable Voltage	VEN	Vee		Vee+ 0.8	V	2
Transmit Disable Assert Time				10	us	
Receiver section						
Differential data output swing	Vout,pp	300		850	mV	3
Data output rise time	tr	28			ps	4
Data output fall time	tf	28			ps	4
LOS Fault	VLOS fault	Vcc-1.3		VccHOST	V	5
LOS Normal	VLOS norm	Vee		Vee+0.8	V	5
Power Supply Rejection	PSR	100			mVpp	6

Notes:

- 1) Connected directly to TX data input pins. AC coupled thereafter.
- 2) Or open circuit.
- 3) Into 100 ohms differential termination
- 4) 20 – 80 %.
- 5) Loss of Signal is LVTTTL. Logic 0 indicates normal operation; logic 1 indicates no signal detected.
- 6) Receiver sensitivity is compliant with power supply sinusoidal modulation of 20 Hz to 1.5 MHz up to specified value applied through the recommended power supply filtering network.



Pin Descriptions

pin	Name	Description	Note
1	V-EET	Transmitter Ground (Common with Receiver Ground)	1
2	T-FAULT	Transmitter Fault.	2
3	T-DIS	Transmitter Disable. Laser output disabled on high or open.	3
4	SDA	2-wire Serial Interface Data Line	4
5	SCL	2-wire Serial Interface Clock Line	4
6	MOD_ABS	Module Absent. Grounded within the module	4
7	RS0	Rate Select 0	5
8	LOS	Loss of Signal indication. Logic 0 indicates normal operation.	6
9	RS1	No connection required	1
10	VEER	Receiver Ground (Common with Transmitter Ground)	1
11	VEER	Receiver Ground (Common with Transmitter Ground)	1
12	RD-	Receiver Inverted DATA out. AC Coupled	
13	RD+	Receiver Non-inverted DATA out. AC Coupled	
14	VEER	Receiver Ground (Common with Transmitter Ground)	1
15	VCCR	Receiver Power Supply	
16	VCCT	Transmitter Power Supply	
17	VEET	Transmitter Ground (Common with Receiver Ground)	1
18	TD+	Transmitter Non-Inverted DATA in. AC Coupled.	
19	TD-	Transmitter Inverted DATA in. AC Coupled.	
20	VEET	Transmitter Ground (Common with Receiver Ground)	1



Product Size Display

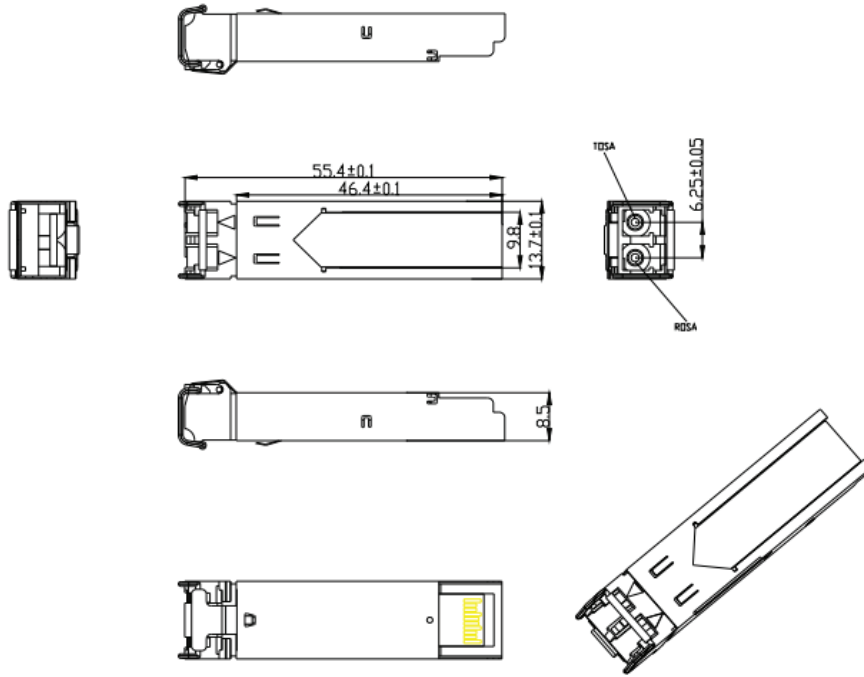

Technical Specification of:
SAE-TGSS2733/3327-40